

marathon[®]
Motors



MAR3/MAR3T IE3 CAST IRON MOTORS CATALOGUE

REGAL[®]

MAR3/MAR3T IE3 EFFICIENCY IP66 CAST IRON MOTORS

INTRODUCTION	3
Standards and specifications	3
MECHANICAL DESIGN	4
PROTECTION	5
Materials and construction	5
TERMINAL BOX	6
Cooling	6
BEARINGS	6
Lubrication	7
Standard ball bearing maximum radial forces Fr [Kn]	7
Standard ball bearing at DE / NDE maximum axial forces [kN]	7 - 8
Vibration	8
Balancing	8
Noise	8
ELECTRICAL DESIGN	9
Voltage and frequency	9
Temperature and altitude	9
Rotation	10
Duty	10
Connection	11
Starting	11
VVVF drives	12
Insulation	12
Thermal protection	12
Speed at partial loads	13
Current at partial loads	13
Torque characteristics	13
INSTALLATION, OPERATION & MAINTENANCE	13 - 15
PERFORMANCE DATA	16 - 17
DIMENSIONS	18 - 21
SLIDE RAILS	21
MODIFICATIONS, VARIATIONS AND OPTIONAL EXTRAS	22
Terminal box	22
Bearings	22
Shafts	22
Environmental considerations	22
Special performance	22
VVVF drives	22
TESTING SERVICES	22

INTRODUCTION

This catalogue details the complete range of Marathon® MAR3 series motors. Standard MAR3 motors are three phase squirrel cage Totally Enclosed Fan Cooled (TEFC), with IEC frame sizes from 80 to 280 (higher on request), with CENELEC frame allocation as standard. They combine excellent electrical characteristics with the robust strength of cast iron.

The standard design includes single speed 2,4 and 6 pole enclosed to IP66.

All units are supplied with F Class insulation, with temperature rise being limited to less than 80K (unless otherwise marked). This provides the end user with a wide safety margin under general operating conditions.

Additional protection is provided by installation of thermistors in all units from 160 frame upward to continuously protect the winding.

The conservative rating of Marathon type MAR3 motors provides additional operational safeguards, ensures long unit life, and renders this series inherently suitable for most arduous mining, industrial or agricultural applications.

In addition we also offer motors wound with H Class insulation, and temperature rise still limited to 80K.

STANDARDS AND SPECIFICATIONS

The main dimensions and rated outputs of Marathon® MAR3 motors generally conform to International Standards IEC60034, IEC60072.

EFFICIENCY

The MAR3 motor range meets the requirements of IE3 efficiency limits of IEC60034-30-1.

OPTIONS

PRODUCT CODE SPECIFICATION

When placing an order, the motor product code should be specified. The product code of the motor is composed in accordance with the following example:

M	3	2	0	0	1	5	0	3	M	A	R	3		/	3	8	6
1	2	3	4					9	10				14	Suffix			

POSITION 1

M = metric frame size]

POSITION 2

Winding design

3 = Standard three phase motors

POSITION 3

Number of poles

2 = 2 poles

4 = 4 poles

6 = 6 poles

POSITIONS 4 TO 8

Rated power output*

(kW x 100)

* Refers to high speed for 2 speed motors

POSITION 9

Mounting arrangements

1 = V1

3 = B3

4 = B3/B5

5 = B5

7 = B14A

POSITIONS 10 TO 13

Series

MAR3 = Marathon® MAR3 series

POSITIONS 14...*

Series variation

Blank = Standard

H = H Class insulation

L = LHS terminal box

T = Top terminal box

F = Flying leads

* Multiple letters indicate multiple variation.

SUFFIX

Winding design

/385 = 380V / 50Hz

/415 = 415V / 50Hz

Blank = 400V / 50Hz

/A05 = 1000V / 50Hz

/B05 = 1100V / 50Hz





/386 = 380V / 60Hz

MECHANICAL DESIGN

MOUNTINGS

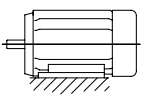
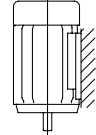
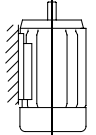
Marathon® MAR3 motors are available in the mounting arrangements listed in the table below:

Foot mount

 <p>B3 (IM1001) [80 - 280]</p>	 <p>V5 (IM1011) [71 - 280]</p>	 <p>V6 (IM1031) [71 - 280]</p>
 <p>B6 (IM1051) [71 - 180]</p>	 <p>B7 (IM1061) [71 - 180]</p>	 <p>B8 (IM1071) [71 - 180]</p>

Large flange

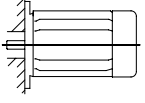
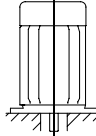
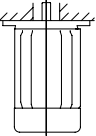
 <p>B5 (IM3001) [71 - 250]</p>	 <p>V1 (IM3011) [71 - 315]</p>	 <p>V3 (IM3031) [71 - 180]</p>
---	---	---

Large flange and feet

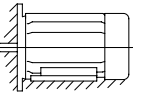
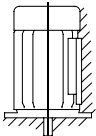
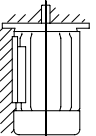
 <p>B3/B5 (IM2001) [80 - 280]</p>	 <p>V1/V5 (IM2011) [71 - 180]</p>	 <p>V3/V6 (IM2031) [71 - 180]</p>
--	--	--

Small flange (face)

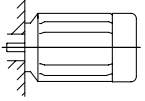
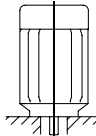
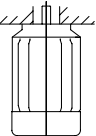
 <p>B14 (IM3601) [80 - 112]</p>	 <p>V18 (IM3611) [80 - 112]</p>	 <p>V19 (IM3631) [80 - 112]</p>
--	--	--

Small flange (face) and feet

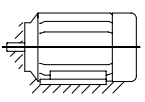
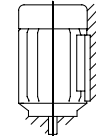
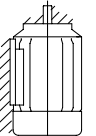
 <p>B3/B14 (IM2101) [80 - 112]</p>	 <p>V5/V18 (IM2111) [80 - 112]</p>	 <p>V6/V19 (IM2131) [80 - 112]</p>
---	---	---

Note: Bearing arrangement may require review for vertical shaft mounting.
Please inform Regal if motor requires vertical mounting.

PROTECTION

FOR VERTICALLY MOUNTED MOTORS

Motors to be mounted with the shaft vertically down must be provided with a suitable cover (available on request) to ensure foreign bodies are prevented from entering the motor.

Special care is necessary in fitting protective covers to ensure air flow is not impeded (refer to Cooling section on page 7).

To maintain IP rating, special additional measures may be required to protect the motor against the ingress of water or foreign bodies. Please contact Regal for further information.

AGAINST SOLAR RADIATION

High solar radiation will result in undue temperature rise.

In these circumstances motors should be screened from solar radiation by placement of adequate sunshades which do not inhibit air flow.

DEGREE OF PROTECTION

Standard level of enclosure protection for all MAR3 frame sizes for both motor and terminal box is IP66.

Enclosure designations comply with IEC or AS60529. The enclosure protection required will depend upon the environmental and operational conditions within which the motor is to operate.

IP standards explanation

IP	6	6
1-2	3	4

POSITIONS 1 AND 2

International protection rating prefix

POSITION 3

First characteristic numeral

Degree of protection of access against approach to live parts or contact with live or moving parts (other than smooth rotating shafts and the like) inside the enclosure, and degree of protection of equipment within the enclosure against the ingress of solid foreign bodies.

- 4** = *Protected against solid object greater than 1.0 mm:* Wires or strips of thickness greater than 1.0 mm, solid objects exceeding 1.0 mm
- 5** = *Dust protected:* Ingress of dust is not totally prevented but it does not enter in sufficient quantity to interfere with satisfactory operation of the equipment.
- 6** = *Dust tight:* No ingress of dust.

POSITION 4

Second characteristic numeral

- 4** = *Protected against splashing water:* Water splashed against the enclosure from any direction shall have no harmful effect.
- 5** = *Protected against water jets:* Water projected by a nozzle against the enclosure from any direction shall have no harmful effect.
- 6** = *Protected against heavy seas:* Water from heavy seas or water projected in powerful jets (larger nozzle and higher pressure than second numeral 5) shall not enter the enclosure in harmful quantities.

MATERIALS AND CONSTRUCTION

Element	Motor frame size
	90 - 280
Frame	Cast iron
Endshields	Cast iron
Terminal box	Cast iron
Fan	Plastic
Fan cowl	Sheet steel
Fasteners	Corrosion protected

SHAFT

MAR3 motors have standard shaft extension lengths and are provided with captive key and drilled and tapped hole. Non standard shaft extensions are available upon special order, with shaft design outlined on a detailed drawing.

Shaft extension run out, concentricity and perpendicularity to face of standard flange mount motors, comply with normal grade tolerance as specified in IEC 60072-1 and AS1359. Precision grade tolerance is available upon special order.

FINISH

Standard MAR3 motor color is RAL 5012 Light Blue. Other colors are also available. All castings and steel parts are provided with a prime coat of rust-resistant paint.

The finishing coat of enamel paint is sufficient for normal conditions, however special paint systems can be provided to accommodate stringent requirements for motors in corrosive environments. Special coatings are needed to resist such substances as acid, salt water and extreme climatic conditions.

Different colors and paint systems apply for varieties as described later in this catalogue.

TERMINAL BOX

MAR3 motors have a cast iron terminal box with a one piece nitrile rubber barrier gasket between terminal box and motor, and a flat gasket under the terminal box lid. The earthing arrangement is available within the terminal box.

As standard, the terminal box is mounted on the side of the motor for MAR3 and on the top of motor for MAR3T. Motors are also available with terminal boxes on the right hand side or left hand side when viewed from drive end.



* Indicates conduit entry position

Conduit entries for motors are provided tapped, with thread details set out below.

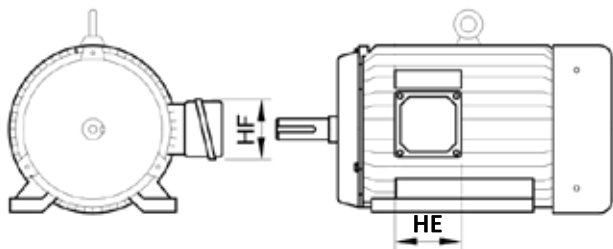

Motor frame	Dimensions		Entry/pitch	Number of entries
	HE	HF		
80 - 100	116	124	M20 x 1.5	2
112 - 132	126	134	M25 x 1.5	2
160	166	186	M32 x 1.5	2
180	166	186	M40 x 1.5	2
200 - 255	202	222	M50 x 1.5	2
250 - 280	226	254	M50 x 1.5	2

Motors can be fitted with optional extended leads.

The terminal box can be rotated through 4 positions, 90° apart. Terminal boxes are fitted with conduit entries with entry from bottom (standard), top, NDE or DE (if not hindered by the mounting flange).

COOLING

MAR3 motors are totally enclosed fan cooled (TEFC) over an externally ribbed frame, with free movement of internal air by rotation of rotor blades, which is in accordance with IC411 of IEC 60034-6 and AS1359.106.

Cooling air flows from the non-drive-end to the drive end. The fan is independent of the direction of rotation of the motor.

When the motor is installed care should be taken not to impede the air flow into the motor cowl. As a guide, the following minimum dimension BL should be adopted.

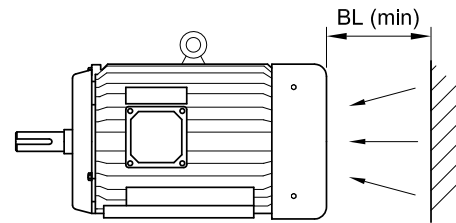

Motor frame	Dimension BL [mm]
80-100	15
112-132	30
160-180	40
200-280	50
315-355	65

BEARINGS

As standard, frame sizes 80 to 132 have high quality deep groove ball bearings with full contact seals. Bearings are prepacked with grease which, under normal operating conditions, provide a high degree of operational reliability. Frame sizes 160 to 280 have high quality bearings with facilities to enable replenishment of the lubricant during operation. Grease nipples are fitted to endshields with the grease relief chute blanked off by a removable plate.

Greater axial forces can be tolerated if the motors are provided with angular contact ball bearings. Note that in such cases, the axial force must operate in one direction.

Frame	Drive end	Non-drive end
80	6204-2Z	6204-2Z
90	6205-2Z	6205-2Z
100	6206-2Z	6206-2Z
112	6206-2Z	6206-2Z
132	6208-2Z	6208-2Z
160	6309	6309
180	6311	6311
200	6312	6312
225-2	6312	6312
225-4,6,8	6313	6312
250	6314	6313
280-2	6314	6314
280-4,6,8	6317	6314

HIGH CAPACITY BEARINGS

For frame sizes 160 to 280 in applications with increased radial force, cylindrical roller bearings can be substituted for ball bearings at the drive end., When a roller bearing is fitted to the D-end, the N-end ball bearing is locked with a circlip to prevent axial movement. Note that the use of roller bearings is not recommended for 2 pole motors.

LUBRICATION

MAR3 motors standard bearings are lubricated with lithium based rolling contact bearing grease suitable for operation within the cooling air temperature range of -20°C to +55°C. For operation outside this temperature range special lubricants are required.

Special lubricants or additional maintenance may be required in the case of motors exposed to comparatively high degrees of pollution, high humidity, increased or changed bearings loads, or prolonged continuous operation.

STANDARD BALL BEARING

Maximum Radial Forces Fr [kN]

Radial Force (50Hz L10h 20000H)			
Frame	Pole	Horizontal	
		Xo	X1/2
80	2	0.64	0.58
	4	0.72	0.65
	6	0.84	0.76
	8	0.98	0.79
90	2	0.66	0.6
	4	0.76	0.69
	6	0.9	0.81
	8	1.03	0.94
100	2	0.94	0.85
	4	1.03	0.93
	6	1.22	1.1
	8	1.4	1.26
112	2	1.66	1.5
	4	1.96	1.72
	6	2.24	1.76
	8	2.58	1.8
132	2	1.94	1.75
	4	2.25	2.03
	6	2.58	2.33
	8	2.88	2.6
160	2	2.5	2.25
	4	2.87	2.58
	6	3.2	2.65
	8	3.81	2.76
180	2	4.27	3.87
	4	3.98	3.61
	6	4.7	4.15
	8	5.06	4.1

200	2	4.01	3.67
	4	4.57	4.19
	6	5.19	4.75
	8	5.81	5.31
225	2	5.23	4.81
	4	5.92	5.33
	6	6.67	6.01
	8	7.54	6.18
250	2	5.12	4.66
	4	5.52	5.03
	6	6.48	5.91
	8	7.15	6.51
280	2	4.92	4.54
	4	6.41	5.91
	6	7.37	6.79
	8	7.57	6.98

The table shows the Permissible Radial Forces in (N), assuming zero axial force and standard ball bearing. The values are based on normal conditions at 50Hz and calculated at 20K working hours. Reduce the values by 10% for 60Hz speeds

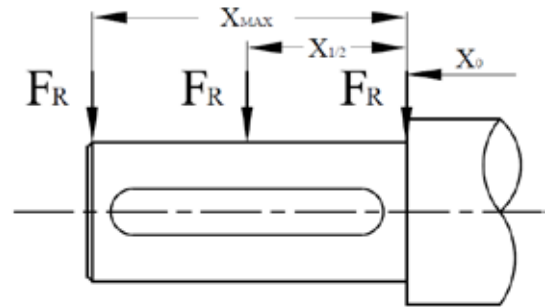

STANDARD BALL BEARING AT DE / NDE

Maximum Axial Forces [kN]

Axial Force (50Hz L10h 20000H)			
Frame	Pole	Horizontal	
		Push	Pull
80	2	0.26	0.42
	4	0.35	0.56
	6	0.45	0.7
	8	0.55	0.83
90	2	0.37	0.43
	4	0.51	0.59
	6	0.63	0.71
	8	0.76	0.86
100	2	0.37	0.59
	4	0.5	0.81
	6	0.65	1.02
	8	0.78	1.19
112	2	0.5	1.1
	4	0.68	1.47
	6	0.96	1.94
	8	1.07	2.15

**STANDARD BALL BEARING AT DE / NDE
Maximum Axial Forces [kN] (Con.)**

Axial Force (50Hz L10h 20000H)			
Frame	Pole	Horizontal	
		Push	Pull
132	2	0.72	1.32
	4	0.99	1.81
	6	1.22	2.2
	8	1.37	2.45
160	2	2.4	1.69
	4	2.95	2.25
	6	3.4	2.7
	8	3.85	3.15
180	2	3.2	2.3
	4	3.9	3
	6	4.65	3.75
	8	5.2	4.35
200	2	3.55	2.55
	4	4.45	3.45
	6	5.2	4.2
	8	6	5
225	2	3.85	2.75
	4	5.2	4.3
	6	6.4	5.6
	8	6.4	5.6
250	2	4.3	3.5
	4	5.3	4.45
	6	6.4	5.6
	8	7.3	6.5
280	2	4.15	3.35
	4	6.8	5
	6	7.6	6.8
	8	8.6	7.6

The table shows the Permissible Axial Forces in (N), assuming zero radial force and standard ball bearing. The values are based on normal conditions at 50Hz and calculated at 20K working hours. Reduce the values by 10% for 60Hz speeds.

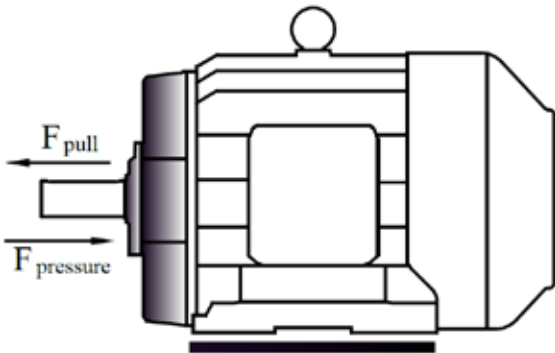

VIBRATION

MAR3 motors fall within the limits of vibration severity set out in standard IEC 60034-14 which are listed below. As specified in the standard, these values relate to rotating machinery measured in soft suspension.

VIBRATION SEVERITY LIMIT, LEVEL N

Motor frame	Maximum RMS vibration velocity [mm/s]
71	1.6
80	1.6
90	1.6
100	1.6
112	1.6
132	1.6
160	2.2
180	2.2
200	2.2
225	2.2
250	2.2
280	2.2

BALANCING

Rotors have been dynamically balanced with a half key. Pulleys or couplings used with motors must also be appropriately balanced.

NOISE

Noise levels for MAR3 motors comply with limits set by IEC 60034.9. MAR3 sound pressure levels at 1 metre (data relates to motors tested at no load) are as set out in the table below.

Motor frame	Sound pressure level dB(A) at 1m.		
	2 Pole	4 Pole	6 Pole
80	67	58	54
90	78	66	63
100	82	70	64
112	83	72	70
132	85	75	73
160	87	77	73
180	88	80	77
200	90	83	80
225	92	84	80
250	92	85	82
280	94	88	85

ELECTRICAL DESIGN

As standard, MAR3 motors have the following design and operating parameters. Performance data is based on this standard. Any deviation should be examined and performance values altered in accordance with the information provided in this section.

- Three phase, 400V, 50Hz
- Ambient cooling air temperature, 40°C
- Altitude 1000m
- Duty cycle S1 (continuous)
- Rotation Clockwise viewed from drive end
- Connection 230 volt Delta/400 volt Star (3kW and below)
400 volt Delta/690 volt Star (4kW and above)

VOLTAGE AND FREQUENCY

Standard MAR3 motors are designed for a power supply of three phase 400V, 50Hz. Motors can be manufactured for any supply between 100V and 1100V and frequencies other than 50Hz. Standard MAR motors wound for a certain voltage at 50Hz can also operate at other voltages at 50Hz and 60Hz without modification, subject to the changes in their data (see table).

Motor wound for 50Hz at rated voltage -	Connected to	Data ¹⁾ in percentage of values at 50Hz and rated voltage							
		Output	r/min	I _N	I _L /I _N	T _N	T _L /T _N	T _B /T _N	
380V	400V 50Hz	100	100	95	110	100	110	110	
	380V 60Hz	100	120	98	83	83	70	85	
	400V 60Hz	105	120	98	90	87	80	90	
	415V 60Hz	110	120	98	95	91	85	93	
	440V 60Hz	115	120	100	100	96	95	98	
	460V 60Hz	120	120	100	105	100	100	103	
400V	380V 50Hz	100	100	105	91	100	90	90	
	415V 50Hz	100	100	96	108	100	108	108	
	400V 60Hz	100	120	98	83	83	70	85	
	415V 60Hz	104	120	98	89	86	75	88	
	440V 60Hz	110	120	98	95	91	85	93	
	460V 60Hz	115	120	100	100	96	93	98	
	480V 60Hz	120	120	100	105	100	100	103	

Note: Not applicable for motors with F class temperature rise. This table is not applicable for hazardous area motors.

- ¹⁾ I_N = Full load current
- I_L/I_N = Locked rotor current/ full load current
- T_B/T_N = Breakdown torque/ full load torque
- T_N = Full load torque
- T_L/T_N = Locked rotor torque/ full load torque

Standard torque values for alternative supplies are obtainable only with special windings. For these purpose-built motors the performance data is the same as for 400V motors except for the currents which are calculated with the accompanying formula:

$$I_x = \frac{400 \times I_N}{U_x}$$

Where:

- I_x = Current
- I_N = Full load current at 415 volt
- U_x = Design voltage

TEMPERATURE AND ALTITUDE

Rated power specified in the performance data tables apply for standard ambient conditions of 40°C at 1000m above sea level. Where temperature or altitude differ from the standard, multiplication factors in the table below should be used.

Ambient temp.	Temp. factor	Altitude above sea level	Altitude factor
30°C	1.06	1000m	1.00
35°C	1.03	1500m	0.98
40°C	1.00	2000m	0.94
45°C	0.97	2500m	0.91
50°C	0.93	3000m	0.87
55°C	0.88	3500m	0.82
60°C	0.82	4000m	0.77

$$\text{Effective Power} = \text{Rated Power} \times \text{Temp. Factor} \times \text{Altitude Factor}$$

Example 1

Effective Power required = 15kW
 Air temperature = 50°C (factor 0.93)
 Altitude = 2500 metres (factor 0.91)

$$\text{Rated power required} = \frac{15}{0.93 \times 0.91} = 17.7\text{kW}$$

The appropriate motor is one with a rated power above the required, being 18.5kW.

Example 2

Rated power = 11kW
 Air temperature = 50°C (factor 0.93)
 Altitude = 1500 metres (factor 0.98)

$$\text{Effective Power} = 11 \times 0.93 \times 0.98 = 10.0\text{kW}$$

ROTATION

For clockwise rotation, viewed from drive end, standard three phase MAR3 and MAR3T motor terminal markings coincide with the sequence of the phase line conductors.

For counter clockwise rotation, viewed from drive end, two of the line conductors have to be reversed. This is made clear in the accompanying table.

Non-standard MARL3 series motors with the terminal box located on the left, viewed from drive end, have a counter-clockwise rotation for corresponding markings. Reversing two of the line conductors will reverse the rotation to clockwise.

Terminal box location (viewed from drive end)	Sequential connection of L1, L2 and L3	Direction of rotation
Right or Top	U1 V1 W1	Clockwise
	V1 U1 W1	Counter-clockwise
Left	V1 U1 W1	Clockwise
	U1 V1 W1	Counter-clockwise

DUTY

MAR3 motors are supplied suitable for S1 operation (continuous operation under rated load).

DUTY CYCLES

S1 CONTINUOUS DUTY

Operation at constant load of sufficient duration for thermal equilibrium to be reached.

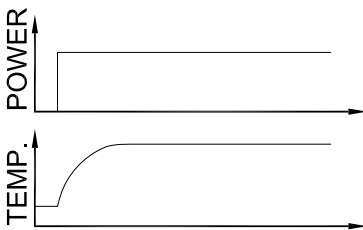

S2 SHORT - TIME DUTY

Operation at constant load during a given time, less than that required to reach thermal equilibrium, followed by a rest (de-energised) period of sufficient duration to allow machine temperatures to reduce to within 2K of the rated inlet coolant temperature.

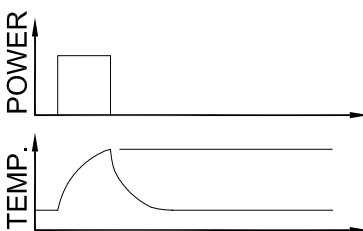

S3 INTERMITTENT PERIODIC DUTY WITH INSIGNIFICANT STARTING TIME

A sequence of identical duty cycles where each consists of a period of operating at constant load and a period at rest. The cycle is such that the starting current does not significantly affect the temperature rise.

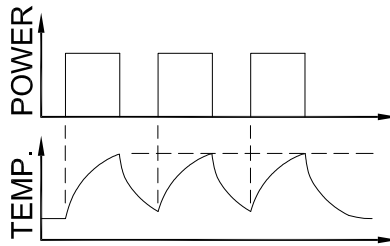

S4 INTERMITTENT PERIODIC DUTY WITH SIGNIFICANT STARTING TIME

Sequence of identical duty cycles where each cycle consists of a significant period of starting, a period of operation at full load and a period of rest.

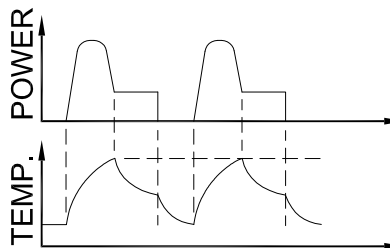

S5 INTERMITTENT PERIODIC DUTY WITH INFLUENCE OF RUNNING UP PERIOD AND ELECTRIC BRAKING

As S4, but with each cycle including a period of rapid electric braking.

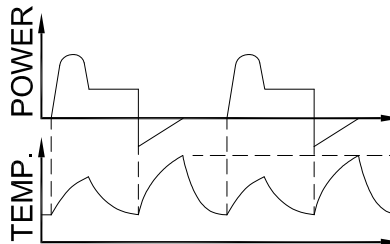

S6 CONTINUOUS PERIODIC DUTY

A sequence of identical duty cycles, each cycle consisting of a period of operation at no-load. There is no rest or de-energised period.

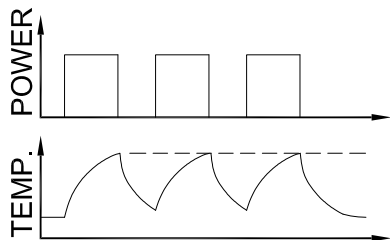

S7 CONTINUOUS PERIODIC DUTY WITH STARTING AND ELECTRIC BRAKING

As S6, with each cycle including a period of starting and a period of electric braking.

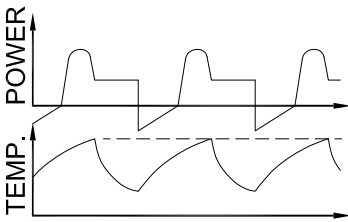

CONNECTION

A motor's rated voltage must agree with the power supply line-to-line voltage. Care must therefore be taken to ensure the correct connection to the motor terminals.

INTERNAL CONNECTIONS, VOLTAGES AND VF DRIVE SELECTION

Standard terminal connections for motors 3.0kW and below is 230V delta / 400V star. These motors are designed for 400V Direct On Line (D.O.L.) starting, when connected in the star configuration. They are also suitable for operation with 230V three phase variable frequency drives, when connected in the delta configuration.

Standard terminal connections for motors 4.0kW and above is 400V delta / 690V star. These motors are designed for 400V D.O.L. starting, when connected in the delta configuration. They are also suitable for operation with 400V three phase variable frequency drives. Alternatively, they can be operated D.O.L. in the star configuration from a 690V supply or with a 690V variable frequency drive. In this case the drive must be supplied with an output sine wave filter to protect the winding insulation. These size motors are also suitable for 400V star-delta starting as described below.

Motor connected for D.O.L. starting with bridges in place for star connection (3.0kW and below)

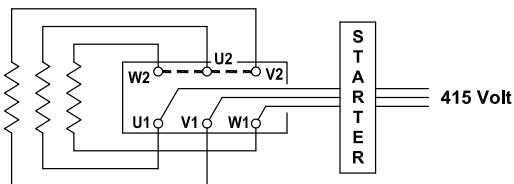

Motor connected for D.O.L. starting with bridges in place for delta connection (4.0kW and above).

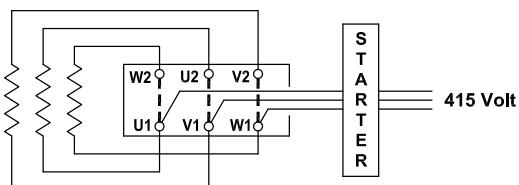

STARTING

All of the following starter options are available and are best supplied together with the motor.

D.O.L. STARTERS

When an electric motor is started by direct connection to the power supply "D.O.L.", it draws a high current, called the "starting current," which is approximately equal in magnitude to the locked rotor current I_L . As listed in the performance data, locked rotor current can be up to 8 times the rated current I_N of the motor. In circumstances where the motor starts under no load or where high starting torque is not required, it is preferable to reduce the starting current by one of the following means.

STAR - DELTA STARTING

MAR3 motors 4.0kW and above are suitable for the star-delta starting method. Through the use of a star-delta starter, the motor terminals are connected in the star configuration during starting, and reconnected to the delta configuration when running.

The benefits of this starting method are a significantly lower starting current, to a value about 1/3 of the "D.O.L." starting current, and a corresponding starting torque also reduced to about 1/3 of its "D.O.L." value. It should be noted that a second current surge occurs on changeover to the delta connection. The level of this surge will depend on the speed the motor has reached at the moment of changeover.

ELECTRONIC SOFT STARTERS

Through the use of an electronic soft starter, which controls such parameters as current and voltage, the starting sequence can be totally controlled. The starter can be programmed to limit the amount of starting current. By limiting the rate of the current increase the startup time is extended. This starting method is particularly suitable for centrifugal loads (fans and pumps).

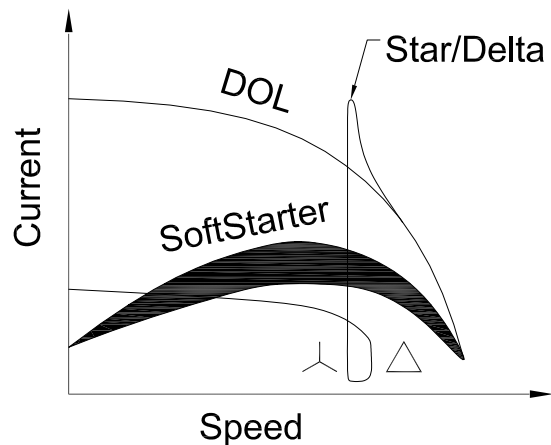

VVVF DRIVES

The MAR3 motor performs excellently without cogging at low speed when operating in conjunction with a Variable Voltage Variable Frequency (VVVF) drive. VVVF drives are primarily recognized for their ability to manipulate power from a constant 3 phase 50/60Hz supply converting it to variable voltage and variable frequency power. This enables the speed of the motor to be matched to its load in a flexible and energy efficient manner. The only way of producing starting torque equal to full load torque with full load current is by using VVVF drives. The functionally flexible VVVF drive is also commonly used to reduce energy consumption on fans, pumps and compressors and offers a simple and repeatable method of changing speeds or flow rates.

For operation below 25Hz, motor cooling fan efficiency drops significantly. Hence, in constant torque applications, a separately driven cooling fan should be fitted to provide sufficient cooling of the motor.

For operation between 25Hz and 50Hz speed range, the motor is capable of delivering full rated torque with its standard fan.

For operation above 50Hz, all MAR3 motors are capable of delivering constant rated power up to 60Hz. However, most of these motors are suitable to run and deliver constant power at much higher frequencies than 60Hz to a maximum of 100Hz. In the case of applications between 60Hz and 100Hz, please contact Regal for advice on suitability.

The MAR3 range of motors will operate without modification on VVVF drives; however, under certain conditions, additional features should be considered (see EDM Concerns). The graph below shows the MAR3 motors' loadability with a frequency converter:

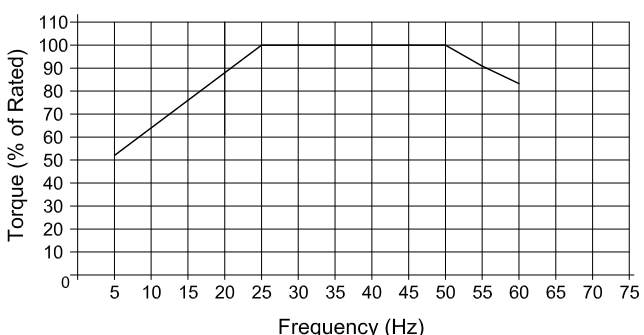

EDM CONCERNS

Capacitive voltages in the rotor can be generated due to an effect caused by harmonics in the waveform, causing voltage discharge to earth through the bearings. This discharge results in etching of the bearing running surfaces. This effect is known as Electrical Discharge Machining (EDM). It can be controlled with the fitment of appropriate filters to the drive.

To further reduce the effect of EDM, an insulated non drive bearing can be used. Regal recommends the use of insulated bearings for all motors 315 frame and above.

INSULATION

Standard MAR3 series motors are wound with F class insulation and winding designs limit the temperature rise to 80K (unless otherwise noted) for which B Class insulation would normally be sufficient. The use of F class insulation provides an additional safety margin of 25K, as shown in the accompanying table, together with an extended operating life.

	Insulation class		
	B	F	H
Max. permissible winding temp. (°C)	130	155	180
Less ambient temp. (°C)	-40	-40	-40
Less hotspot allowance (K)	-10	-10	-15
Equals max. permissible temp. rise (K)	80	105	125
Less max. design temperature rise (K)	-80	-80	-80
Equals min. safety margin (K)	-	25	45

Due to their conservative design, many sizes in the MAR3 range of motors have temperature rises considerably less than 80K and therefore provide even greater safety margins.

THERMAL PROTECTION

Motors can be protected against excessive temperature rise by inserting, at various positions within the windings, thermal probes which can either give a warning signal or cut off the supply to the motor in the event of a temperature abnormality.

The units fitted to MAR3 motors, frame sizes 160 and above, are PTC thermistors. These thermovisible resistors, with positive temperature co-efficient, are fitted one per phase, series connected and are terminated in a terminal strip located in the terminal box. Trip temperature is 150°C. Additional 130°C thermistors can be fitted as an option for alarm connection.

SPEED AT PARTIAL LOADS

The relationship between motor speed and degree of loading on an MAR motor is approximately linear up to the rated load. This is expressed graphically in the accompanying drawing.

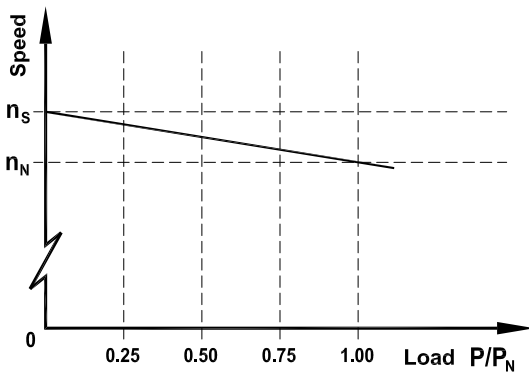

Where:

- n_N = full load speed
- n_s = synchronous speed
- P/P_N = partial load factor

CURRENT AT PARTIAL LOADS

Current at partial loads can be calculated using the following formula:

$$I_x = \frac{P_{out_x}}{\sqrt{3} \times U_N \times \cos \phi_x \times \eta_x} \times 10^5$$

Where:

- I_x = partial load current (amps)
- P_{out_x} = partial load (kW)
- U_N = rated voltage
- $\cos \phi_x$ = partial load power factor
- η_x = partial load efficiency (%)

TORQUE CHARACTERISTICS

Typical characteristics of torque behaviour relative to speed are shown in the torque speed curve example below.

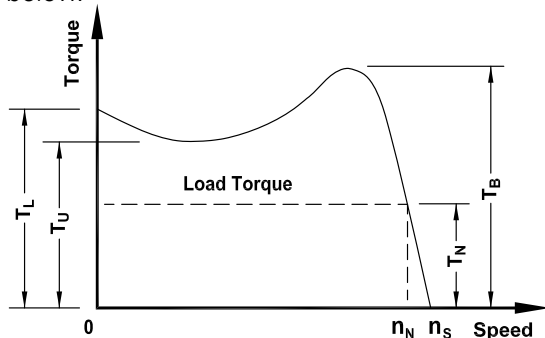

Where:

- T_N = full load torque
- T_L = locked rotor torque
- T_U = pull-up torque
- T_B = break down torque
- n_N = full load speed
- n_s = synchronous speed

MAR3 motors all exceed the minimum starting torque requirements for Design N (Normal torque) as specified in IEC60034-12, and in most cases meet the requirements of Design H (High torque).

Rated torque can be calculated with the following formula:

$$T_N = \frac{9550 \times P_N}{n_N}$$

Where:

- T_N = full load torque (Nm)
- P_N = full load output power (kW)
- n_N = full load speed (r/min)

INSTALLATION, OPERATION & MAINTENANCE

For a copy of the Installation, Operation & Maintenance manual, please contact Regal or download from our website at www.regalaustralia.com

The Marathon® MAR3 series motors are designed and manufactured to be robust and reliable with minimal maintenance. The following items should be taken into consideration to ensure a trouble free installation and reliable running throughout the motor's life.

INSPECTION

Marathon® motors are delivered through safe and reliable transport in appropriate packing as to remain in as manufactured condition during transit. On receipt of the motor, thoroughly inspect the unit for any transit damage, if need be in the presence of an insurance surveyor. Any equipment damage or shortfall should be immediately advised to the nearest Regal office.

Check the following:

- Rating plate details and enclosure are as ordered.
- Shaft turns freely (in absence of shaft locking clamp).
- Condensation drain holes are in the correct position for the motor mounting application (they should be located at the lowest point of the motor when it is in its operating position).
- If the winding is Insulation Resistance (IR) tested to earth, ensure that the thermal protectors are not inadvertently damaged. (The thermistor leads should be shorted together whilst IR testing takes place).

STORAGE

When the motor is not for immediate use store as follows:

- Clean and dry location.
- Free from vibration (vibration can damage bearings).
- Shaft locking clamps, where supplied, are fitted securely.
- Remove shaft locking clamps and turn rotor by one full rotation at least once a fortnight and replace shaft locking clamps.
- Anti-condensation heaters, where fitted, should be energised if the environment is likely to be damp.

INSTALLATION

The following items should be considered on installation to ensure reliable operation of the motor:

SURROUNDINGS

- Ensure that the motor is properly protected against ingress of oil, water or dust especially if construction work is in progress around the motor.
- Ensure air intake is not obstructed. Refer to dimension BL in the catalogue.
- When installing hazardous location motors, make sure that the zone and gas group or dust and temperature classification on motor nameplate are complied with.

MOUNTING

- Bed plates or slide rails should be firmly fixed to a solid, level foundation to ensure the motor remains rigid and vibration free.
- Shims or packers (if required) must be of adequate size and placed adjacent to and between base fixing screws.
- Protective transport coatings on shafts and/or flanges must be removed prior to connection to the driven load.
- A light coating of grease to shafts and/or flanges will inhibit corrosion during service and assist removal of pulleys or couplings.

OPERATION

- Before running the motor make sure that the terminal box lid is closed and secured with appropriate clearance to live parts.
- Make sure that appropriate earthing is done.
- Make sure that the coupling and/or transmission is adequately guarded for safety.
- Check the mounting bolts and/or flanges are firmly secured.
- Make sure of no loose objects around that may be sucked by the cooling fan on the motor.
- Make sure that the load applied is within the nameplate specification.
- Make sure that the ambient temperature is inside 40°C or nameplate specification.

- Avoid frequent starting of motor. Refer to motor catalogue or nearest Regal office for recommendation on frequency and duration of starts.
- Check that the running current on no load and full load are reasonably balanced within 10% of the average and record the figures in the log book for future reference. Note that the current imbalance can be higher, typically 10 times the voltage imbalance if there is an imbalance in supply voltage.

NUMBER OF STARTS PER HOUR

The number of starts per hour is dependant on the inertia of the driven load and the load torque demand. When high inertia load is applied (flywheel, heavy fan etc) please refer to your nearest Regal office for advice. A guide to generally acceptable starts per hour would be as per table.

For greater number of starts per hour, please contact your nearest Regal office for advice.

Starts per Hour				
Frame	2 Pole	4 Pole	6 Pole	8 Pole
80*	20	40	40	-
90	16	30	40	-
100	16	30	40	40
112	16	30	40	40
132	10	20	25	25
160	10	20	25	25
180	8	15	20	20
200	6	12	12	12
225	5	10	10	10
250	4	8	8	8
280	3	6	6	6
315	3	4	4	4

* 20 Starts / Hour

PERMITTED STARTING TIME

In respect to the temperature rise of the motor, starting time (i.e., from rest to operational speed) should not exceed the time indicated in the following table. Motor must be allowed to cool prior to each start.

Frame	Starting method	Maximum starting time [sec]			
		2 pole	4 pole	6 pole	8 pole
80	D.O.L.	15	26	40	-
90	D.O.L.	10	15	25	-
100	D.O.L.	12	13	18	40
112	D.O.L.	10	10	18	35
132	D.O.L.	14	12	12	25
160-355	D.O.L.	15	15	20	20
160-355	Star-delta	45	45	60	60

SEALED BEARINGS

The required replacement interval for sealed bearings is generally determined by the grease life which is dependant on operating temperature, operating speed, the limiting speed of the bearing and the type of grease. Under normal operating conditions the following relationship applies:-

$$\log t = 6.54 - 2.6 \frac{n}{N} - (0.025 - 0.012 \frac{n}{N}) T$$

Where:

t = Average grease life (hours)

n = Speed (RPM)

N = Bearing limiting speed with grease lubrication (RPM)

T = Operating temperature (°C)

For further information, please contact your nearest Regal office for advice.

OPEN (REGREASABLE) BEARINGS

It should be noted that, for motors fitted with ball and roller bearings, the lubrication intervals for both bearings should be based on the roller bearing data.

The re-lubrication intervals recommended are calculated on the basis of normal working conditions.

NOTE: Under arduous conditions please contact Regal or the bearing manufacturers catalogue. Air operated grease guns should not be used.

Replenishment of grease media should be by means of a hand held grease gun whilst motor is running with relief plate removed.

MAINTENANCE

Reliable, trouble free operation of a motor needs regular maintenance. Exact maintenance needs vary based on the site conditions. To obtain reliable service from the motor, the following maintenance schedule may be used as a guide.

- A. Ensure air intake space is unobstructed.
- B. On a weekly basis use an air hose to ensure all air ways are clear and free of dust.
- C. Once every month, check motor for condensation. Replace drain plugs before starting if they are blocked or found missing.
- D. Do not wash the motor down unless it is IP66 rated.
- E. On a quarterly basis-
 - (i) Check the motor terminals for tightness and proper contact,
 - (ii) If terminal lug/s are discoloured, re-terminate with fresh lugs,
 - (iii) Check operation of starting equipment, ensuring all terminations are tight.
 - (iv) Check mechanical operation of thermal overload relays, if any,

- (v) Check mechanical operation of thermistor relays, if fitted,
 - (vi) Check operation of anti-condensation heaters, if fitted.
- F. On a six monthly basis, in addition to the items in 'E' -
- (i) Check winding resistance between supply terminals and compare to original value and enter in log book.
 - (ii) Check supply voltage at motor terminals and record in log book.
 - (iii) Check bearings for abnormal noise/overheating.
- G. On an annual basis, in addition to the items in 'E' and 'F' -
- (i) Re-grease the bearings as recommended in the following table. Frames 71-132 use sealed bearings. Frames 160-355 use open re-greasable bearings. When re-greasing bearings ensure that the correct type of grease is used. If in doubt about the existing grease type, clean out the old grease thoroughly from bearings and bearing housings, prior to regreasing.
- NOTICE:** NEVER MIX GREASE OF DIFFERENT TYPES. Use lithium based grease such as Shell®* Alvania®* R3 or equivalent unless otherwise specified.
- (ii) Completely disassemble stator, rotor apart and clean thoroughly.
 - (iii) Check bearings for wear/damage – replace as necessary.
 - (iv) Check all bolts and nuts for cracks or damage – replace as necessary.
 - (v) Check all holding down bolts for signs of fatigue or damage – replace as necessary.
 - (vi) After re-assembly, check and record in the log book-
Insulation resistance by megger
No load current and voltages
Full load current and voltages
Ensure that these figures compare well with the original records in the log book.
 - (vii) Check and ensure that the cooling fan is operational.

*Alvania and Shell are believed to be the trademarks of Shell Brands International AG and are not owned or controlled by Regal Beloit Corporation.

PERFORMANCE DATA

MAR3 SERIES THREE PHASE IP66 F CLASS INSULATION B CLASS TEMPERATURE RISE

Type	Rated Output		Efficiency[%] at % F.L.				Power factor at % F.L.				Current		Torque			Weight (kg)
	kW	RPM	125	100	75	50	125	100	75	50	FL [A]	IL /IN	FL [Nm]	TL /TN	TB /TN	
2 POLE MOTORS																
MAR3-80M1-2	0.75	2880	79.2	80.7	81.5	80.7	0.89	0.82	0.79	0.74	1.63	6.2	2.5	2.4	2.9	18
MAR3-80M2-2	1.1	2870	79.7	83.1	84.3	81.2	0.82	0.78	0.73	0.55	2.5	6.0	3.7	2.3	2.6	20
MAR3-90S-2	1.5	2885	82.2	84.3	85.6	86.0	0.86	0.83	0.79	0.72	3.1	7.4	5	2.7	2.9	24
MAR3-90L-2	2.2	2915	85.7	86.4	86.5	86.7	0.86	0.83	0.82	0.80	4.5	8.8	7.3	3.5	4.1	27
MAR3-100L-2	3	2880	86.8	87.4	87.4	85.8	0.88	0.86	0.82	0.72	5.8	7.5	9.9	2.6	3.3	35
MAR3-112M-2	4	2915	87.0	87.8	88.3	88.5	0.88	0.88	0.87	0.84	7.5	8.8	13.1	2.8	3.1	42
MAR3-132S1-2	5.5	2930	88.7	89.2	89.3	89.1	0.91	0.89	0.88	0.85	10	8.6	17.9	3.0	3.4	64
MAR3-132S2-2	7.5	2915	88.3	89.7	90.2	89.6	0.92	0.92	0.91	0.85	13.2	8.1	24	2.5	2.9	70
MAR3-160M1-2	11	2950	91.4	91.7	91.9	92.1	0.90	0.90	0.89	0.88	19.3	8.0	36	2.7	3.2	140
MAR3-160M2-2	15	2950	92.0	92.3	92.6	92.6	0.89	0.89	0.88	0.87	26.4	8.5	49	2.9	3.2	154
MAR3-160L2-2	18.5	2945	91.9	92.4	92.6	92.9	0.91	0.91	0.90	0.90	32	8.2	60	3.0	3.0	162
MAR3-180M-2	22	2960	93.5	93.6	93.6	93.5	0.91	0.90	0.89	0.88	37.7	9.8	71.2	3.4	4.1	198
MAR3-200L2-2	30	2965	93.3	93.3	93.3	93.3	0.87	0.86	0.85	0.83	53.9	8.1	96.6	2.8	3.5	260
MAR3-200L2-2	37	2960	93.4	93.9	94.1	93.3	0.91	0.92	0.91	0.85	62.2	7.9	119	2.6	3.3	280
MAR3-225SM-2	45	2970	94.6	94.7	94.8	94.9	0.90	0.90	0.89	0.88	76.3	9.1	145	2.8	3.6	330
MAR3-250SM-2	55	2975	94.2	94.3	94.4	94.4	0.90	0.89	0.88	0.87	94.4	9.2	177	2.6	3.4	390
MAR3-280SM-2	75	2985	94.7	94.8	94.8	94.7	0.88	0.88	0.87	0.86	130.1	8.3	240	2.7	3.4	498
MAR3-280SM-2	90	2980	95.0	95.1	95.1	95.1	0.89	0.89	0.88	0.87	154.4	8.4	289	3.2	3.5	680
4 POLE MOTORS																
MAR3-80M2-4	0.75	1450	82.9	83.0	81.8	77.7	0.75	0.68	0.59	0.46	1.9	5.5	5	2.3	2.7	18
MAR3-90S-4	1.1	1430	81.8	84.0	85.4	84.7	0.78	0.75	0.69	0.57	2.6	5.5	7.3	2.1	2.5	25
MAR3-90L-4	1.5	1445	83.1	85.3	86.3	84.4	0.79	0.75	0.69	0.54	3.4	6.8	10	2.3	2.8	27
MAR3-100L1-4	2.2	1455	86.4	87.1	87.0	85.1	0.88	0.80	0.73	0.61	4.6	7.9	14.5	3	3.5	34
MAR3-100L2-4	3	1460	86.0	87.6	88.2	87.7	0.83	0.78	0.71	0.62	6.4	6.6	19.9	2.4	2.5	39
MAR3-112M-4	4	1455	87.8	88.9	89.3	87.9	0.83	0.81	0.79	0.68	8.3	8.4	26.3	2.9	3.3	45
MAR3-132S-4	5.5	1460	87.6	89.1	89.9	89.3	0.86	0.85	0.80	0.68	10.6	7.9	35.9	2.4	2.8	70
MAR3-132M-4	7.5	1460	89.2	90.6	91.5	90.3	0.83	0.80	0.74	0.56	14.9	6.1	48.9	2.2	2.4	80
MAR3-160M-4	11	1470	91.0	91.3	91.4	91.5	0.84	0.83	0.81	0.79	21.1	7.9	71.5	2.1	2.9	130
MAR3-160L-4	15	1470	91.9	92.1	92.3	92.3	0.84	0.83	0.81	0.78	28.4	8.6	97.4	2.4	3	150
MAR3-180M-4	18.5	1465	91.5	92.4	92.8	91.3	0.86	0.84	0.78	0.61	34.4	6.6	120	2.5	2.6	190
MAR3-180L-4	22	1475	93.0	93.7	94.1	93.8	0.88	0.86	0.82	0.72	39.7	7.2	143	2.1	2.7	210
MAR3-200L-4	30	1475	93.9	94.4	94.7	94.2	0.87	0.85	0.82	0.72	53.8	7.8	194	2.8	2.9	280
MAR3-225SM-4	37	1480	93.6	94.2	94.5	94.0	0.86	0.84	0.80	0.71	67.8	6.9	239	2.3	3.4	320
MAR3-225SM-4	45	1475	93.6	94.3	94.8	94.6	0.87	0.85	0.82	0.74	80.5	7.5	290	2.5	2.7	350
MAR3-250SM-4	55	1485	95.2	95.6	95.8	95.8	0.85	0.83	0.82	0.79	100.4	8.2	354	2.9	3.1	450
MAR3-280SM-4	75	1485	95.8	96.1	96.4	96.6	0.87	0.87	0.86	0.85	130.1	7.4	481	2.4	3.1	590
MAR3280SM-4	90	1485	95.0	95.1	95.2	95.2	0.88	0.87	0.87	0.85	156.7	7.6	577	2.6	3.3	670

PERFORMANCE DATA

MAR3 SERIES THREE PHASE IP66 F CLASS INSULATION B CLASS TEMPERATURE RISE

Type	Rated Output		Efficiency[%] at % F.L.				Power factor at % F.L.				Current		Torque			Weight (kg)
	kW	RPM	125	100	75	50	125	100	75	50	FL [A]	IL /IN	FL [Nm]	TL /TN	TB /TN	
6 POLE MOTORS																
MRA3-90S-6	0.75	950	77.9	79.2	79.1	76.0	0.76	0.69	0.60	0.47	1.97	4.7	7.6	1.8	2.1	26
MRA3-90L-6	1.1	950	79.4	82.1	82.3	80.1	0.72	0.72	0.62	0.49	2.7	5.7	11.1	2.6	2.9	28
MRA3-100L-6	1.5	950	81.0	83.5	85.2	84.2	0.75	0.72	0.67	0.55	3.6	5.2	15.1	2.3	2.4	36
MRA3-112M-6	2.2	975	84.3	85.5	85.8	84.2	0.77	0.72	0.63	0.50	5.2	7.2	21.8	2.4	3	42
MRA3-132S-6	3	975	85.1	86.0	85.9	83.8	0.78	0.73	0.64	0.51	7	7.2	29.4	2.3	2.7	60
MRA3-132M1-6	4	975	85.3	87.1	86.8	84.5	0.73	0.74	0.64	0.50	9	4.9	39.2	2.4	2.7	72
MRA3-132M2-6	5.5	975	86.2	87.6	88.3	87.6	0.81	0.77	0.71	0.59	11.8	7.6	53.9	2.4	2.7	79
MAR3-160M-6	7.5	980	87.7	89.1	89.0	87.0	0.78	0.77	0.71	0.58	15.7	6.5	73.1	2.2	2.6	125
MRA3-160L-6	11	980	87.6	89.5	90.4	89.3	0.84	0.83	0.79	0.63	21.3	5.9	107	2.3	2.4	155
MRA3-180L-6	15	980	90.4	91.4	91.8	91.2	0.84	0.82	0.77	0.66	28.9	8.0	146	2.2	2.5	185
MRA3-200L1-6	18.5	980	90.3	91.3	91.7	91.1	0.84	0.83	0.78	0.69	35.5	6.6	179	2.1	2.6	240
MRA3-200L2-6	22	985	90.9	92.3	92.6	91.7	0.82	0.81	0.76	0.64	42.5	6.8	213	2.4	2.7	250
MRA3-225SM-6	30	985	92.0	93.1	93.8	93.2	0.87	0.83	0.84	0.76	56.2	6.0	291	2.3	2.5	300
MAR3-250SM-6	37	985	93.5	93.6	93.8	93.7	0.84	0.83	0.81	0.79	69.1	7.8	359	2.4	3.3	384
MAR3-280SM-6	45	990	93.4	93.6	93.7	93.7	0.85	0.84	0.83	0.81	82.6	7.4	434	2.3	3	419
MAR3-280SM-6	55	990	94.0	94.1	94.2	94.2	0.85	0.84	0.83	0.81	100.6	8.1	531	2.5	3.3	600

DIMENSIONS

MAR3 SERIES THREE PHASE IP66 F CLASS INSULATION B CLASS TEMPERATURE RISE

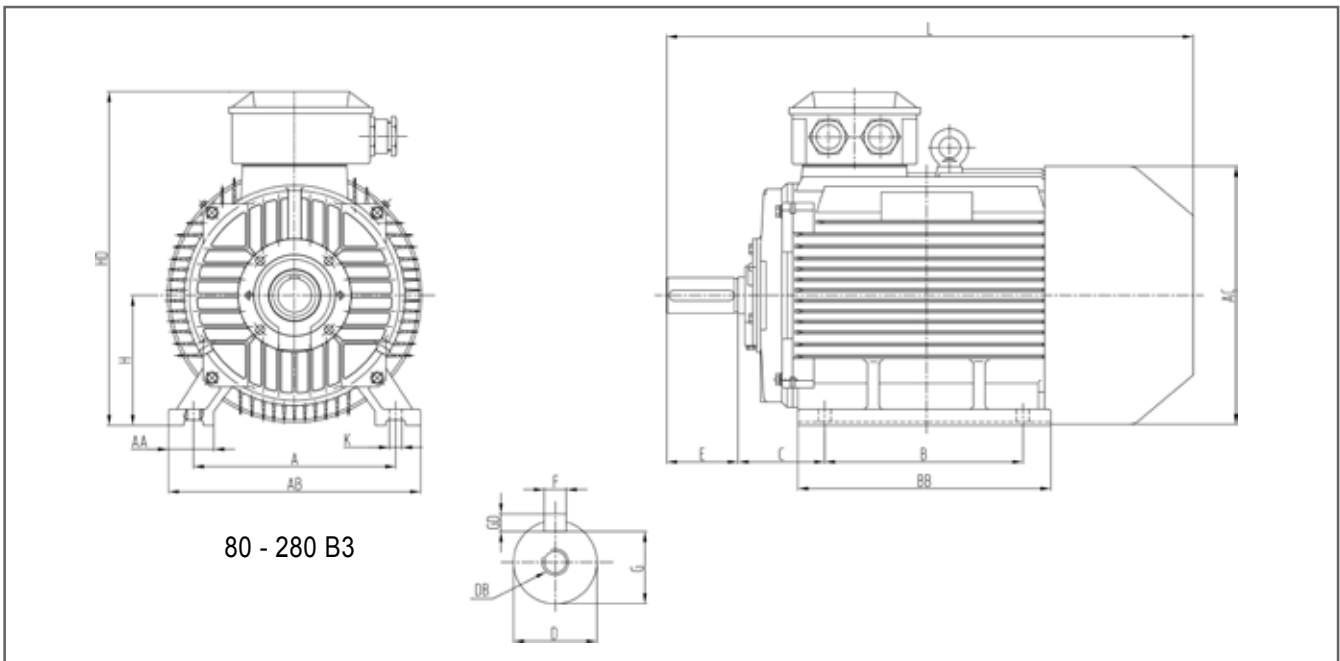
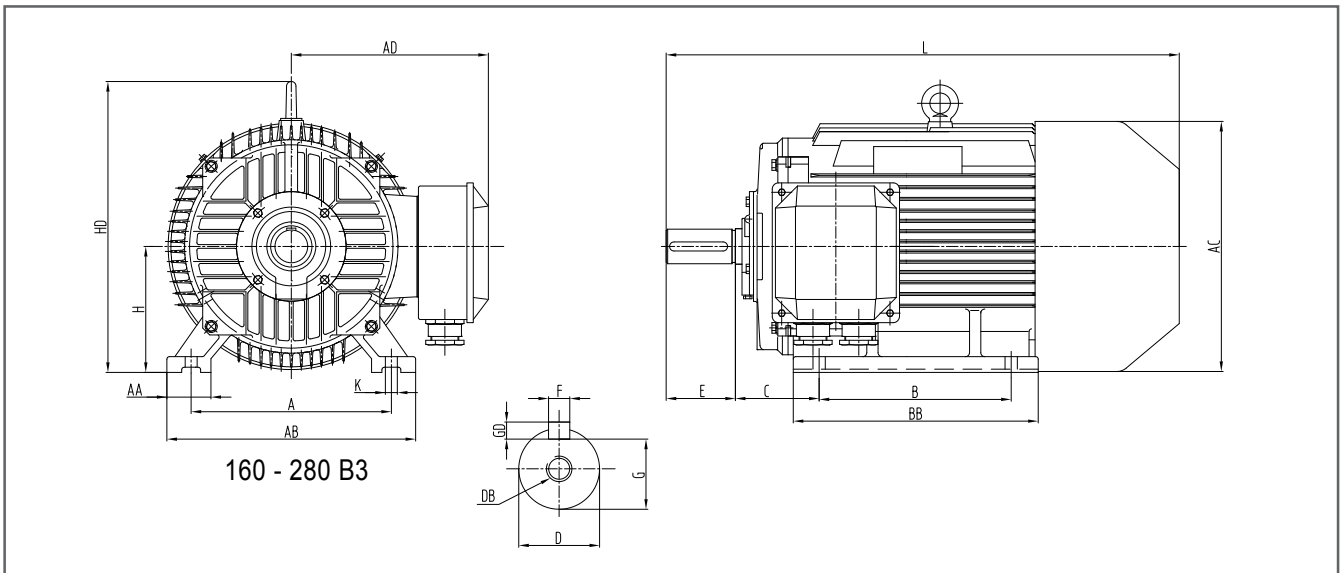
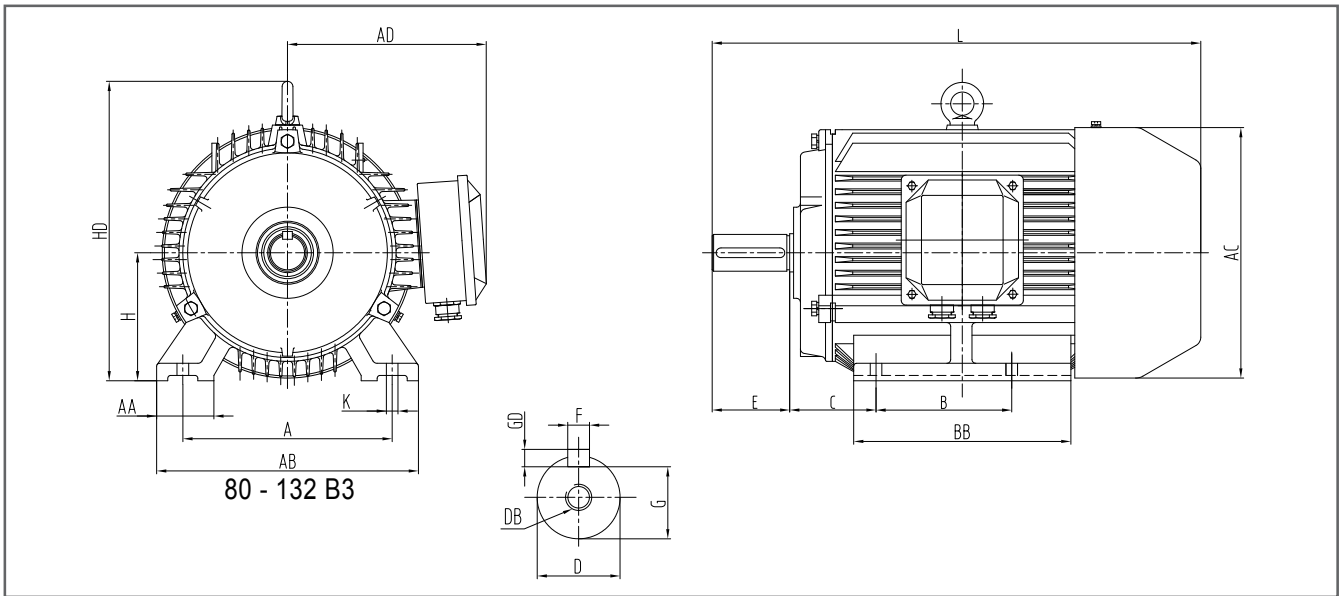

DIMENSIONS

MAR3 SERIES THREE PHASE IP66 F CLASS INSULATION B CLASS TEMPERATURE RISE

MOUNTING DIMENSIONS FOR INSTALLATION B3

Type	Pole	Mounting Dimensions (mm)																			
		A	AA	AB	AC	AD	B	BB	C	D	DB	E	F	GD	G	H	HA	HD-B3	HD-B3T	K	L
80	2,4,6	125	35	160	175	155	100	165	50	19	M6	40	6	6	15.5	80	10	170	230	4x10	320
90S	2,4,6	140	38	175	195	165	100	180	56	24	M8	50	8	7	20	90	14	190	245	4x10	350
90L	2,4,6	140	38	175	195	165	125	208	56	24	M8	50	8	7	20	90	14	190	245	4x10	380
100L	2,4,6	160	42	200	215	175	140	232	63	28	M10	60	8	7	24	100	16	244	270	4x12	440
112M	2,4,6	190	45	226	240	190	140	248	70	28	M10	60	8	7	24	112	15	263	300	4x12	465
132S	2,4,6	216	55	262	275	210	140	224	89	38	M12	80	10	8	33	132	18	312	345	4x12	505
132M	2,4,6	216	55	262	275	210	178	260	89	38	M12	80	10	8	33	132	18	312	345	4x12	550
160M	2,4,6	254	65	314	330	265	210	304	108	42	M16	110	12	8	37	160	20	382	430	4X14.5	665
160L	2,4,6	254	65	314	330	265	254	335	108	42	M16	110	12	8	37	160	20	382	430	4X14.5	700
180M	2,4,6	279	70	349	380	290	241	349	121	48	M16	110	14	9	42.5	180	22	418	465	4X14.5	720
180L	2,4,6	279	70	349	380	290	279	381	121	48	M16	110	14	9	42.5	180	22	418	465	4X14.5	760
200L	2,4,6	311	70	388	420	320	305	389	133	55	M20	110	16	10	49	200	25	462	520	4x18.5	815
225SM*	2	356	75	431	470	345	286/311	393	149	55	M20	110	16	10	49	225	28	510	570	6x18.5	825
225SM	4,6	356	75	431	470	345	286/311	393	149	60	M20	140	18	11	53	225	28	510	570	6x18.5	855
250SM*	2	406	80	484	510	385	311/349	445	168	60	M20	140	18	11	53	250	30	565	635	6x24	915
250SM	4,6	406	80	484	510	385	311/349	445	168	65	M20	140	18	11	58	250	30	565	635	6x24	915
280SM*	2	457	85	542	580	415	368/419	536	190	65	M20	140	18	11	58	280	35	643	695	6x24	1025
280SM	4,6	457	85	542	580	415	368/419	536	190	75	M20	140	20	12	67.5	280	35	643	695	6x24	1035

DIMENSIONS

MAR3 SERIES THREE PHASE IP66 F CLASS INSULATION B CLASS TEMPERATURE RISE

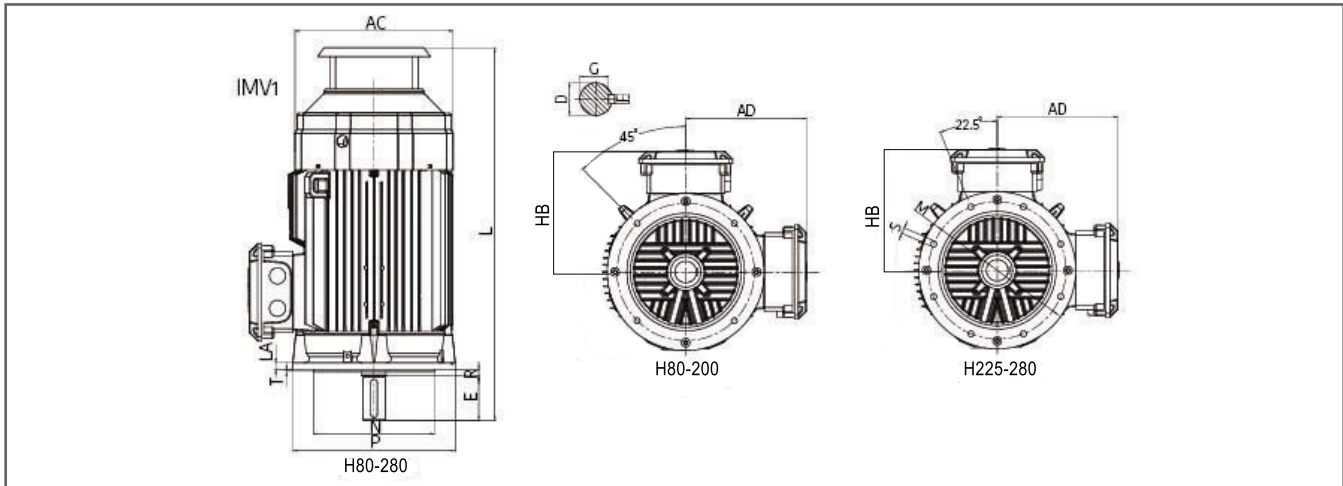

MOUNTING DIMENSIONS FOR INSTALLATION B5

Type	Pole	Mounting Dimensions (mm)															
		AC	AD	D	DB	E	F	GD	G	HB	L	LA	M	P	N	T	S*
80M	2,4,6	175	155	19	M6	40	6	6	15.5	150	320	12	165	200	130	3.5	4x12
90S	2,4,6	195	165	24	M8	50	8	7	20	155	350	12	165	200	130	3.5	4x12
90L	2,4,6	195	165	24	M8	50	8	7	20	155	380	12	165	200	130	3.5	4x12
100L	2,4,6	215	175	28	M10	60	8	7	24	170	440	13	215	250	180	4	4x14.5
112M	2,4,6	240	190	28	M10	60	8	7	24	188	465	14	215	250	180	4	4x14.5
132S	2,4,6	275	210	38	M12	80	10	8	33	213	505	14	265	300	230	4	4x14.5
132M	2,4,6	275	210	38	M12	80	10	8	33	213	550	14	265	300	230	4	4x14.5
160M	2,4,6	330	265	42	M16	110	12	8	37	270	665	16	300	350	250	5	4x18.5
160L	2,4,6	330	265	42	M16	110	12	8	37	270	700	16	300	350	250	5	4x18.5
180M	2,4,6	380	290	48	M16	110	14	9	42.5	285	720	15	300	350	250	5	4x18.5
180L	2,4,6	380	290	48	M16	110	14	9	42.5	285	760	15	300	350	250	5	4x18.5
200L	2,4,6	420	320	55	M20	110	16	10	49	320	815	17	350	400	300	5	4x18.5
225SM*	2	470	345	55	M20	110	16	10	49	345	825	20	400	450	350	5	8x18.5
225SM	4,6	470	345	60	M20	140	18	11	53	345	855	20	400	450	350	5	8x18.5
250SM*	2	510	385	60	M20	140	18	11	53	385	915	22	500	550	450	5	8x18.5
250SM	4,6	510	385	65	M20	140	18	11	58	385	915	22	500	550	450	5	8x18.5
280SM*	2	580	415	65	M20	140	18	11	58	415	1025	22	500	550	450	5	8x18.5
280SM	4,6	580	415	75	M20	140	20	12	67.5	415	1035	22	500	550	450	5	8x18.5

*Note: Frames 80 - 200 have 4 holes at 45deg offset from top. Frames 225 - 280 have 8 holes at 22.5deg offset from top.

DIMENSIONS

MAR3 SERIES THREE PHASE IP66 F CLASS INSULATION B CLASS TEMPERATURE RISE

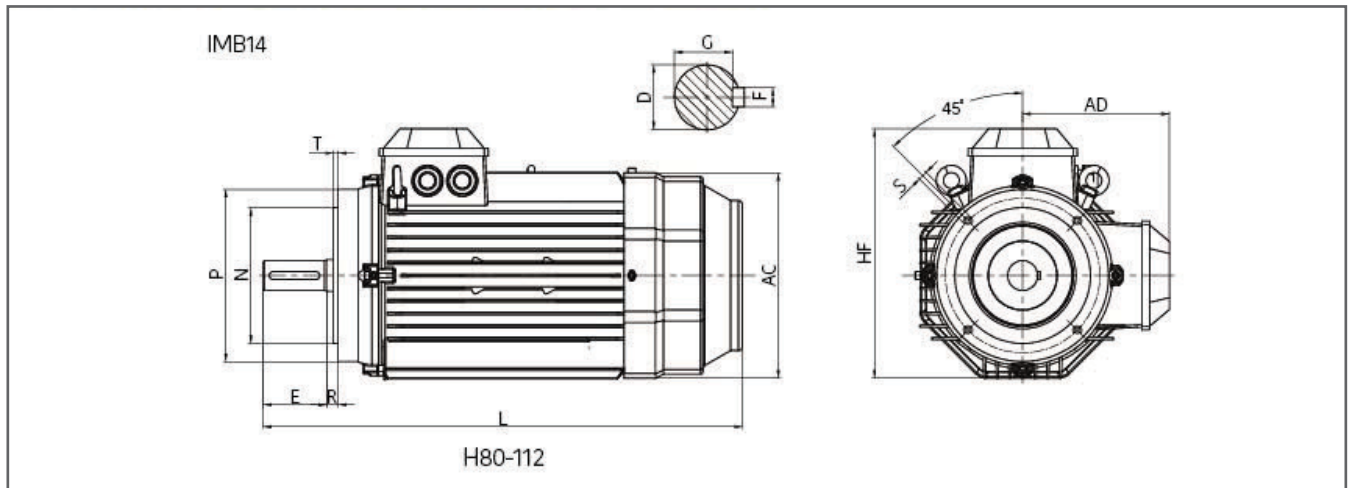

MOUNTING DIMENSIONS FOR INSTALLATION B14

Type	Mounting Dimensions (mm)													
	D	E	F	G	M	N	P	R	S	T	AC	AD	HF	L
80M	19	40	6	15.5	100	80	120	0	4-M6	3	175	145	230	320
90S	24	50	8	20	115	95	140	0	4-M8	3	195	165	245	360
90L	24	50	8	20	115	95	140	0	4-M8	3	195	165	245	390
100L	28	60	8	24	130	110	160	0	4-M8	3.5	215	180	285	455
112M	28	60	8	24	130	110	160	0	4-M8	3.5	240	190	320	485

SLIDE RAILS

Slide rails are designed for motor position adjustment when belt drives are used. Applications include tension adjustment for belt driven equipment.

Regal stocks slide rails to suit frame sizes 80 to 280. Rail sets are manufactured from cast iron and provided with mounting bolts and nuts between motor and rail.

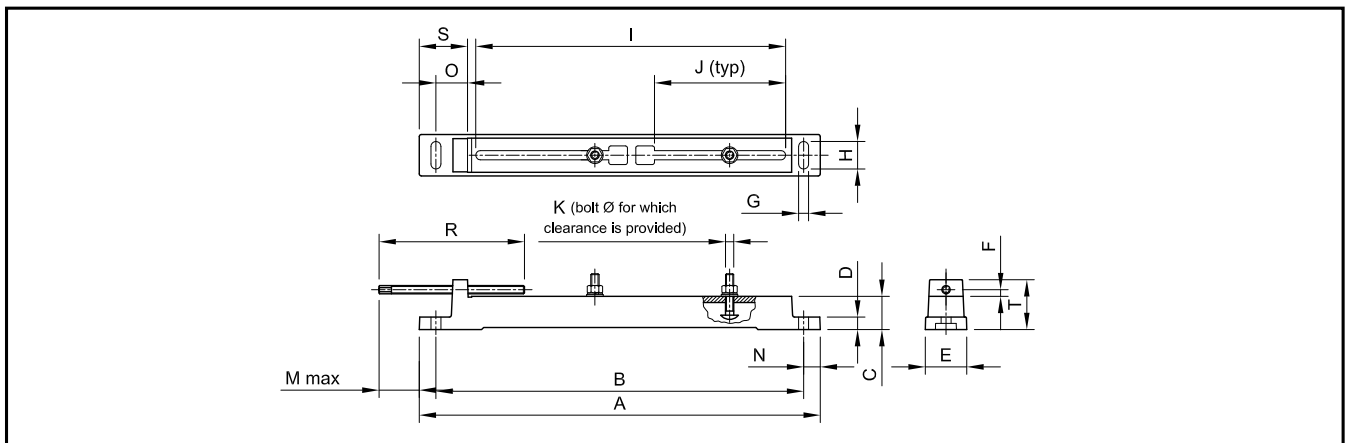

Slide rail product code	To suit motor frame	Dimensions [mm]																	Weight per set [kg]
		A	B	C	D	E	F	G	H	I	J	K	M	N	O	R	S	T	
MR080090	80 & 90	380	328	30	15	48	10	15	25	245	95	8	75	25	40	145	65	50	3
MR100132	100, 112 & 132	475	425	37	19	70	10	14	35	340	150	10	135	26	42	200	68	62	6.5
MR160180	160 & 180	567	515	48	19	72	11	18	35	390	162	12	115	28	57	200	85	70	10
MR200225	200 & 225	790	730	60	32	92	16	20	20	610	265	16	200	30	60	290	90	92	22
MR250280	250 & 280	945	870	70	38	105	16	21	21	725	305	20	240	35	70	350	105	110	40

MODIFICATIONS, VARIATIONS AND OPTIONAL EXTRAS

Regal offers an extensive range of variations and modifications. Some are detailed below. For other requirements please contact Regal.

TERMINAL BOX

MAR3 motors come standard with a terminal box on the top (MAR3T). The following alternatives are available:

- Right hand terminal box (view from drive end) - MAR3
- Left hand terminal box - MAR3L
- Removed terminal box (fitted with a blanking plate and threaded conduit entry. Extended leads, including earth connector) - MAR3F

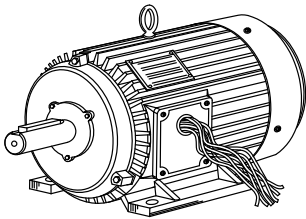

Extended leads: 1.5m
No. of power leads: 3+1 for up to 3kW,
6+1 for 4kW and above

Motor frame	Conduit size
71-132	M25 x 1.5
160-180	M32 x 1.5
200-250	M50 x 1.5
280	M50 x 1.5

BEARINGS

Regal can address applications where bearings need special consideration. Attention may need to be given to the following:

- Bearing monitors
- Alternative bearing types
- Low/high temperature bearing grease
- Oil seals
- Non contact labyrinth seals
- Insulated bearings

SHAFTS

MAR3 motors come standard with a single output shaft to standard dimensions. The following alternatives are available:

- Double shaft extension
- Special shaft extension
- Stainless steel shaft material type

ENVIRONMENTAL CONSIDERATIONS

Where environmental factors need special consideration Regal can provide the following modifications:

- Winding temperature monitors and thermistors
- Anti-condensation heaters
- Separately powered cooling fans
- Tropic proofing
- Special paint finish
- High ambient temperature motors – with H class insulation

SPECIAL PERFORMANCE

Regal has the ability to provide MAR3 motors with special windings. These may include:

- Windings for alternative operating voltages and frequencies.
- Windings designed for increased outputs and short time ratings.

VVVF DRIVES

Two types of VVVF drives kit are available for the MAR3 range to assist in maintaining satisfactory operation.

VVVF DRIVE KIT A - SEPARATELY DRIVEN COOLING FAN (240 & 415V)

This fan should be used when the motor speed is required to be reduced below 25Hz in constant torque mode. For centrifugal fan or pump, no separate cooling fan is required. For all other loads refer to the loadability curve in the section on VVVF Drives, refer page 12.

VVVF DRIVE KIT B - STANDARD MOTOR (EDM)

This kit incorporates a single insulated bearing, normally at the non-drive end, designed to remove the effect of electrical discharge through the bearings.

TESTING SERVICES

Regal can provide both type test certificates and individual motor test reports on any Regal® MAR3 motor.

Type test reports and outline drawings of standard motors are available from Regal.

marathon®

HEAD OFFICE - AUSTRALIA

Regal Beloit Australia Pty Ltd ABN 61 122 303 084
19 Corporate Ave (PO Box 2340)
Rowville VIC 3178, Australia
Customer Service: 1300 888 853
Fax: +61 3 9237 4050
www.regalaustralia.com.au

STATE OFFICES

VICTORIA

19 Corporate Avenue
Rowville VIC 3178
T: 1300 888 853
F: +61 3 9237 4050

NEW SOUTH WALES

8 Bushells Place
Wetherill Park NSW 2164
T: 1300 888 853
F: +61 2 8781 3131

QUEENSLAND

7 Mahogany Court
Willawong QLD 4110
T: 1300 888 853
F: +61 7 3246 3210
CAIRNS (Service • Repairs • Sales)
2/159-161 Newell Street
Bungalow QLD 4870
T: 1300 888 853
F: +61 7 4033 5553

PRESENT IN

MACKAY

SOUTH AUSTRALIA

WESTERN AUSTRALIA

T: 1300 888 853

NEW ZEALAND

Regal Beloit New Zealand Limited
18 Jomac Place Avondale
Auckland, New Zealand
T: 0800 676 722
F: +64 9 820 8504

PRESENT IN

CHRISTCHURCH

ROTORUA

T: 0800 676 722

MALAYSIA

Regal Beloit Malaysia Sdn. Bhd.
Formerly Torin Industries (Malaysia) Sdn. Bhd
No. 6536A Jalan Bukit Kemuning
Batu 6 Seksyen 34
40470 Shah Alam Selangor, Malaysia
T: +60 3 5124 6157
F: +60 3 5121 1467

SINGAPORE

Regal-Beloit Asia Pte. Ltd.
12 Tuas Loop 637346, Singapore
T: +65 6863 3473
F: +65 6863 3476

THAILAND

FASCO Motors (Thailand) Limited
29/7-8 Bangkruey-Sainoi Road Bangkrang
Muang Nonthaburi District
Nonthaburi 11000, Thailand
T: +66 2447 3300
F: +66 2447 3500

APPLICATION CONSIDERATIONS

The proper selection and application of motors, motor controls and components, including the related area of product safety, is the responsibility of the customer. Operating and performance requirements and potential associated issues will vary appreciably depending upon the use and application of such products and components. The scope of the technical and application information included in this publication is necessarily limited. Unusual operating environments and conditions, lubrication requirements, loading supports, and other factors can materially affect the application and operating results of the products and components and the customer should carefully review its requirements. Any technical advice or review furnished by Regal Beloit Australia Pty Ltd and its affiliates with respect to the use of products and components is given in good faith and without charge, and Regal assumes no obligation or liability for the advice given, or results obtained, all such advice and review being given and accepted at customer's risk.

For a copy of our Standard Terms and Conditions of Sale, Disclaimers of Warranty and Limitation of Liability, please contact Customer Service at 1300 888 853 or visit www.regalaustralia.com.au. These terms and conditions of sale, disclaimers and limitations of liability apply to any person who may buy, acquire or use a Regal Beloit Australia Pty Ltd product referred to herein, including any person who buys from a licensed distributor of these branded products.

Regal and Marathon are trademarks of Regal Beloit Corporation (USA) or one of its affiliated companies.

©2018 Regal Beloit Corporation, All Rights Reserved. MCC19005E • SB002E • r1



REGAL®